**Road vehicles — Diagnostics on
Controller Area Networks (CAN) —**

**Part 4:
Requirements for emissions-related
systems**

*Véhicules routiers — Diagnostic sur gestionnaire de réseau de
communication (CAN) —*

Partie 4: Exigences applicables aux systèmes associés aux émissions



Reference number
ISO 15765-4:2005(E)

© ISO 2005

PDF disclaimer

This PDF file may contain embedded typefaces. In accordance with Adobe's licensing policy, this file may be printed or viewed but shall not be edited unless the typefaces which are embedded are licensed to and installed on the computer performing the editing. In downloading this file, parties accept therein the responsibility of not infringing Adobe's licensing policy. The ISO Central Secretariat accepts no liability in this area.

Adobe is a trademark of Adobe Systems Incorporated.

Details of the software products used to create this PDF file can be found in the General Info relative to the file; the PDF-creation parameters were optimized for printing. Every care has been taken to ensure that the file is suitable for use by ISO member bodies. In the unlikely event that a problem relating to it is found, please inform the Central Secretariat at the address given below.

© ISO 2005

All rights reserved. Unless otherwise specified, no part of this publication may be reproduced or utilized in any form or by any means, electronic or mechanical, including photocopying and microfilm, without permission in writing from either ISO at the address below or ISO's member body in the country of the requester.

ISO copyright office
Case postale 56 • CH-1211 Geneva 20
Tel. + 41 22 749 01 11
Fax + 41 22 749 09 47
E-mail copyright@iso.org
Web www.iso.org

Published in Switzerland

Contents

Page

Foreword	iv
Introduction	v
1 Scope	1
2 Normative references	1
3 Terms, definitions, symbols and abbreviated terms	1
4 External test equipment initialization sequence	2
4.1 General	2
4.2 11 bit CAN identifier verification procedure	4
4.2.1 Request message transmit procedure	4
4.2.2 Response handling procedure	5
4.3 29 bit CAN identifier verification procedure	7
4.3.1 Request message transmit procedure	7
4.3.2 Response handling procedure	8
5 Session layer	9
6 Network layer	10
6.1 General	10
6.2 Addressing formats	10
6.3 Data link layer interface	10
6.3.1 CAN identifier requirements	10
6.3.2 Mapping of diagnostic addresses	10
6.4 Network layer parameters	13
6.4.1 Network layer timing parameter values	13
6.4.2 Definition of external test equipment network layer parameter values	13
6.4.3 Maximum number of legislated-OBD ECUs	14
7 Data link layer	14
8 Physical layer	14
8.1 General	14
8.2 External test equipment baudrates	14
8.3 External test equipment CAN bit timing	15
8.3.1 CAN bit timing parameter values	15
8.3.2 Nominal baudrate 250 kBit/s	16
8.3.3 Nominal baudrate 500 kBit/s	17
8.4 External test equipment	17
8.4.1 General	17
8.4.2 CAN interface	18
8.4.3 External-test-equipment cable	20
Bibliography	21

Foreword

ISO (the International Organization for Standardization) is a worldwide federation of national standards bodies (ISO member bodies). The work of preparing International Standards is normally carried out through ISO technical committees. Each member body interested in a subject for which a technical committee has been established has the right to be represented on that committee. International organizations, governmental and non-governmental, in liaison with ISO, also take part in the work. ISO collaborates closely with the International Electrotechnical Commission (IEC) on all matters of electrotechnical standardization.

International Standards are drafted in accordance with the rules given in the ISO/IEC Directives, Part 2.

The main task of technical committees is to prepare International Standards. Draft International Standards adopted by the technical committees are circulated to the member bodies for voting. Publication as an International Standard requires approval by at least 75 % of the member bodies casting a vote.

Attention is drawn to the possibility that some of the elements of this document may be the subject of patent rights. ISO shall not be held responsible for identifying any or all such patent rights.

ISO 15765-4 was prepared by Technical Committee ISO/TC 22, *Road vehicles*, Subcommittee SC 3, *Electrical and electronic equipment*.

ISO 15765 consists of the following parts, under the general title *Road vehicles — Diagnostics on Controller Area Networks (CAN)*:

- *Part 1: General information*
- *Part 2: Network layer services*
- *Part 3: Implementation of unified diagnostic services (UDS on CAN)*
- *Part 4: Requirements for emissions-related systems*

Introduction

This part of ISO 15765 has been established in order to define common requirements for vehicle diagnostic systems implemented on a Controller Area Network (CAN) communication link, as specified in ISO 11898. Although primarily intended for diagnostic systems, it also meets requirements from other CAN-based systems needing a network layer protocol.

To achieve this, it is based on the Open Systems Interconnection (OSI) Basic Reference Model specified in ISO/IEC 7498 and ISO/IEC 10731, which structures communication systems into seven layers. When mapped on this model, the services specified by ISO 15765 are divided into

- unified diagnostic services (layer 7), specified in ISO 15765-3,
- network layer services (layer 3), specified in ISO 15765-2,
- CAN services (layers 1 and 2), specified in ISO 11898,

in accordance with Table 1.

The application layer services covered by ISO 15765-3 have been defined in compliance with diagnostic services established in ISO 14229-1 and ISO 15031-5, but are not limited to use only with them. ISO 15765-3 is also compatible with most diagnostic services defined in national standards or vehicle manufacturer's specifications.

The network layer services covered by ISO 15765-2 have been defined to be independent of the physical layer implemented, and a physical layer is only specified for legislated OBD.

For other application areas, ISO 15765 can be used with any CAN physical layer.

Table 1 — Enhanced and legislated-OBD diagnostic specifications applicable to the OSI layers

Open Systems Interconnection (OSI) layers	Vehicle manufacturer enhanced diagnostics	Legislated on-board diagnostics (OBD)
Diagnostic application	User defined	ISO 15031-5
Application layer	ISO 15765-3	ISO 15031-5
Presentation layer	N/A	N/A
Session layer	ISO 15765-3	N/A
Transport layer	N/A	N/A
Network layer	ISO 15765-2	ISO 15765-4
Data link layer	ISO 11898-1	ISO 15765-4
Physical layer	User defined	ISO 15765-4

Road vehicles — Diagnostics on Controller Area Networks (CAN) —

Part 4: Requirements for emissions-related systems

1 Scope

This part of ISO 15765 specifies requirements for the emissions-related systems of legislated-OBD-compliant controller area networks (CAN), such communications networks consisting of a road vehicle equipped with a single or multiple emissions-related ECUs and external test equipment. It is based on the specifications of ISO 15765-2, ISO 11898-1 and ISO 11898-2, while placing restrictions on those standards for legislated-OBD purposes. It does not specify in-vehicle CAN bus architecture. Legislated-OBD-compliant vehicles are to comply with external test equipment requirements.

2 Normative references

The following referenced documents are indispensable for the application of this document. For dated references, only the edition cited applies. For undated references, the latest edition of the referenced document (including any amendments) applies.

ISO 11898 (all parts), *Road vehicles — Controller area network (CAN)*

ISO 14229-1, *Road vehicles — Unified diagnostic services (UDS) — Part 1: Specification and requirements*¹⁾

ISO 15765-2, *Road vehicles — Diagnostics on Controller Area Networks (CAN) — Part 2: Network layer services*

ISO 15031-5, *Road vehicles — Communication between vehicle and external equipment for emissions-related diagnostics — Part 5: Emissions-related diagnostic services*¹⁾

3 Terms, definitions, symbols and abbreviated terms

For the purposes of this document, the terms and definitions given in ISO 14229-1 and the following symbols and abbreviated terms apply.

C_1, C_2	capacitance of a.c. termination
C_{CAN_H}	capacitance between CAN_H and ground potential
C_{CAN_L}	capacitance between CAN_L and ground potential
C_{DIFF}	capacitance between CAN_H and CAN_L

1) To be published.

L_{CABLE}	max. cable length between OBD connector and external test equipment
R_1, R_2	resistance of a.c. termination
t_{SEG1}	timing segment 1
t_{SEG2}	timing segment 2
t_{SYNCSEG}	synchronization segment
t_{BIT}	bit time
$t_{\text{BIT_RX}}$	receive bit time
$t_{\text{BIT_TX}}$	transmit bit time
t_{TOOL}	external test equipment CAN interface propagation delay (without external test equipment cable delay)
t_{CABLE}	external-test-equipment cable propagation delay (without external test equipment CAN interface delay)
t_{Q}	time quantum
Δf	oscillator tolerance
ECU	electronic control unit
OBD	on-board diagnostics
Prop_Seg	propagation segment
Phase_Seg1	phase segment 1
Phase_Seg2	phase segment 2
SA	source address
SJW	synchronization jump width
SP	nominal sample point
Sync_Seg	synchronization segment
TA	target address

4 External test equipment initialization sequence

4.1 General

The external test equipment shall support the initialization sequence specified in this part of ISO 15765. See Figure 1.

The purpose of the external test equipment initialization sequence is to automatically detect whether the vehicle supports legislated on-board diagnostics on CAN using the physical layer specified in Clause 8. Furthermore, the initialization sequence determines the legislated-OBD ECUs (CAN Id, see 6.3) expected to respond to ISO 15031-5 service 01 hex requests. Note that for each legislated-OBD service that requires the determination of “supported” information, the external test equipment has to update its list of expected responding legislated-OBD ECUs prior to any data parameter requests (see ISO 15031-5 for applicable services). The external test equipment initialization sequence supports single baudrate initialization (e.g. 500 kBit/s) and multiple baudrate initialization (e.g. 250 kBit/s and 500 kBit/s) and is separated into

- a) 11 bit CAN identifier verification procedure (see 4.2), and
- b) 29 bit CAN identifier verification procedure (see 4.3).

The external test equipment initialization sequence contains provisions for legacy vehicles using either CAN (same or different physical layer as defined for legislated OBD) or a different protocol (non-CAN) on the CAN pins of the ISO 15031-3 diagnostic connector.

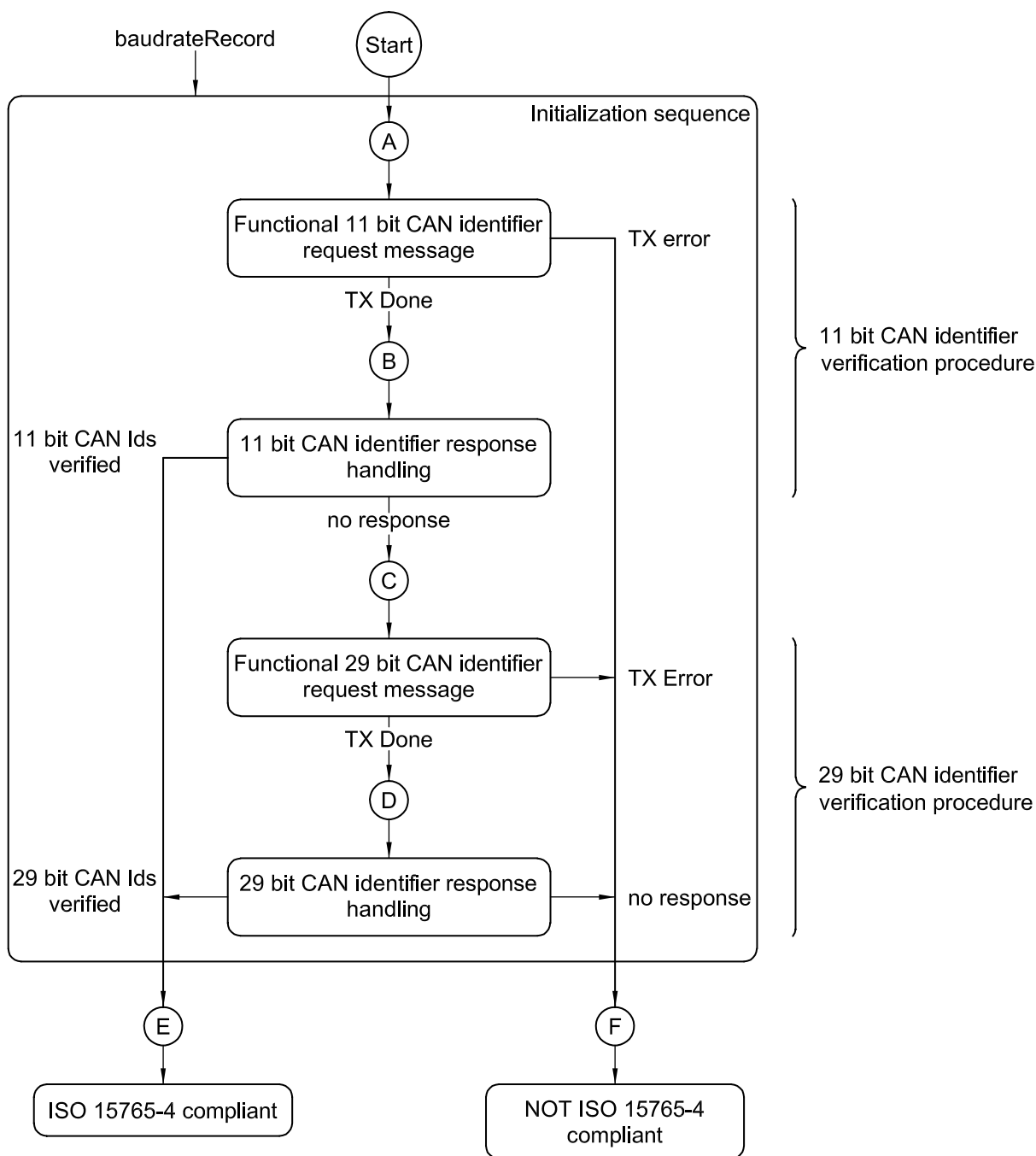

Figure 1 — Initialization sequence — Overview

The parameter baudrateRecord shall be used to specify the type of initialization to be performed. If the baudrateRecord parameter contains a single baudrate, then a single baudrate initialization sequence shall be performed using the specified single baudrate (e.g. 500 kBit/s). If the baudrateRecord parameter contains multiple baudrates, then a multiple baudrate initialization sequence including a baudrate detection procedure shall be performed using the specified multiple baudrates (e.g. 250 kBit/s and 500 kBit/s).

By default the baudrateRecord contains all baudrates specified in 8.3. The default content of the parameter baudrateRecord can be superseded by any other list of baudrates, e.g. single 500 kBit/s baudrate as specified in 8.3.3.

For legislated-OBD baudrates, the external test equipment shall use the appropriate CAN bit timing parameter values defined in 8.3.

The following descriptions of the external test equipment initialization make use of the connectors A to F as shown in Figure 1 to reference certain entry and exit points.

4.2 11 bit CAN identifier verification procedure

4.2.1 Request message transmit procedure

The purpose of the 11 bit CAN identifier verification procedure is to determine whether 11 bit CAN identifiers are being used in legislated-OBD communication and, if multiple baudrates are specified in the baudrateRecord parameter, to determine the baudrate to be used in such communication.

The following transmit procedure shall be used to transmit the request message of the 11 bit CAN identifier verification procedure. The transmit procedure contains provisions for legacy vehicles which use either CAN (same or different physical layer as defined for legislated OBD) or a different protocol (non CAN) on the CAN pins of the ISO 15031-3 diagnostic connector.

Where the vehicle uses a CAN with a physical layer different from that specified for legislated OBD (Clause 8) or a non-CAN protocol on the CAN pins of the OBD connector, the transmit procedure given as follows shall guarantee that in all cases the external test equipment will detect that the vehicle does not support CAN as specified for legislated OBD and will stop the transmission of the request message immediately.

Where the vehicle uses CAN and the physical layer according to Clause 8, the transmit procedure given as follows shall guarantee that in all cases the external test equipment will detect that it uses the wrong baudrate for the transmission of the request message and will stop disturbing the CAN bus immediately. Under normal in-vehicle conditions (i.e. no error frames during in-vehicle communication when the external test equipment is disconnected), the external test equipment will disable its CAN interface prior to the situation where the internal error counters of the OBD ECU(s) reach critical values.

To achieve this, the external test equipment shall support the following features.

- Possibility to stop sending immediately during transmission of any CAN frame. The CAN interface should be disconnected within 12 μ s from reception of a bus error signal. The maximum time for the disconnection is 100 μ s. With the CAN interface disconnected, the external test equipment shall not be able to transmit dominant bits on the CAN bus.
- Possibility to immediately detect any error on the CAN bus.

The procedure shall be performed as follows. See Figure 2.

- a) The external test equipment shall set up its CAN interface using the first baudrate contained in the baudrateRecord. It shall use the CAN bit timing parameter values defined for this baudrate (see 8.3). Following the CAN Interface set-up, it shall connect the CAN Interface to the CAN bus.
- b) The external test equipment shall transmit a functionally addressed service 01 hex request message (read-supported PIDs)²⁾ using the legislated-OBD 11 bit functional request CAN identifier according to 6.3.2.2.

2) See ISO 15031-5 for the request message definition of service 01 hex to read the supported PIDs.

- c) The external test equipment shall check for any CAN error. If the request message is transmitted onto the CAN bus, it shall indicate a successful transmission (connector B).
- d) If a CAN error occurred, the external test equipment shall disconnect its CAN Interface from the CAN bus. With a disconnected CAN interface, the external test equipment shall not be able to transmit dominant bits on the CAN bus. It shall check whether more baudrates are contained in the baudrateRecord. If no further baudrate is contained in the baudrateRecord, it shall indicate that the request was not transmitted successfully (connector F).
- e) If the end of the baudrateRecord is not reached, the external test equipment shall set up its CAN interface using the next baudrate in the baudrateRecord and shall connect its CAN interface to the CAN bus. Following the setup, the external test equipment shall transmit the request message once again [continue from b)].

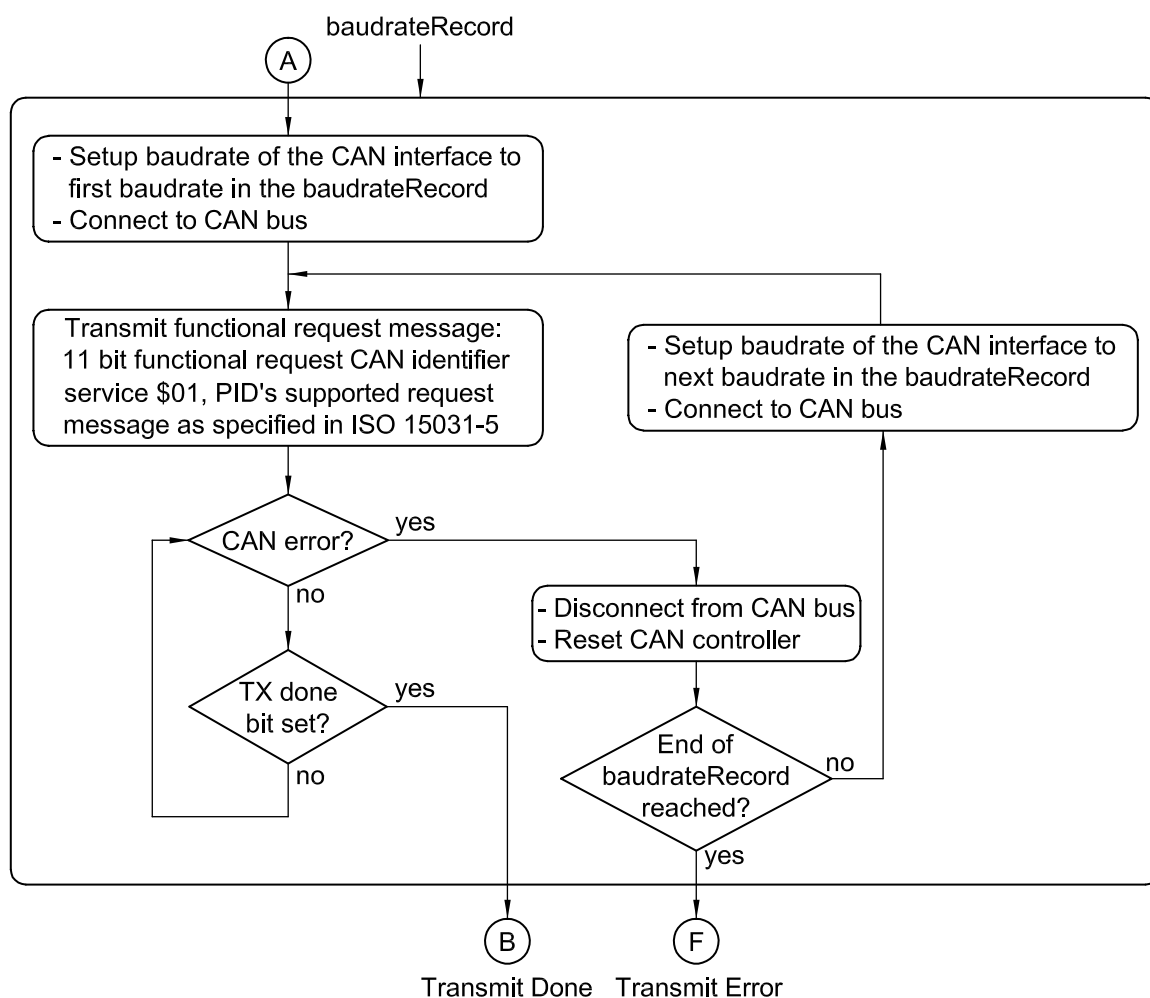

Figure 2 — Initialization sequence — 11 bit CAN identifier request transmission

4.2.2 Response handling procedure

The response handling procedure shall be used to receive 11 bit CAN identifier response messages and indicates that no response message has been received. It shall be performed immediately after the 11 bit CAN identifier request message transmit procedure (4.2.1), as follows. See Figure 3.

- a) If the transmission of the request message was successful (connector B), the external test equipment shall start the $P2_{CAN}$ (see ISO 15031-5) application timer.

- b) If the external test equipment determines a P2_{CAN} timeout then no response message has been started and the external test equipment has verified that 11 bit CAN identifiers are *not* used for legislated-OBD communication (connector C). In addition, this means that the external test equipment has determined that the vehicle supports CAN using the specified physical layer and one of the baudrates contained in the baudrateRecord parameter.

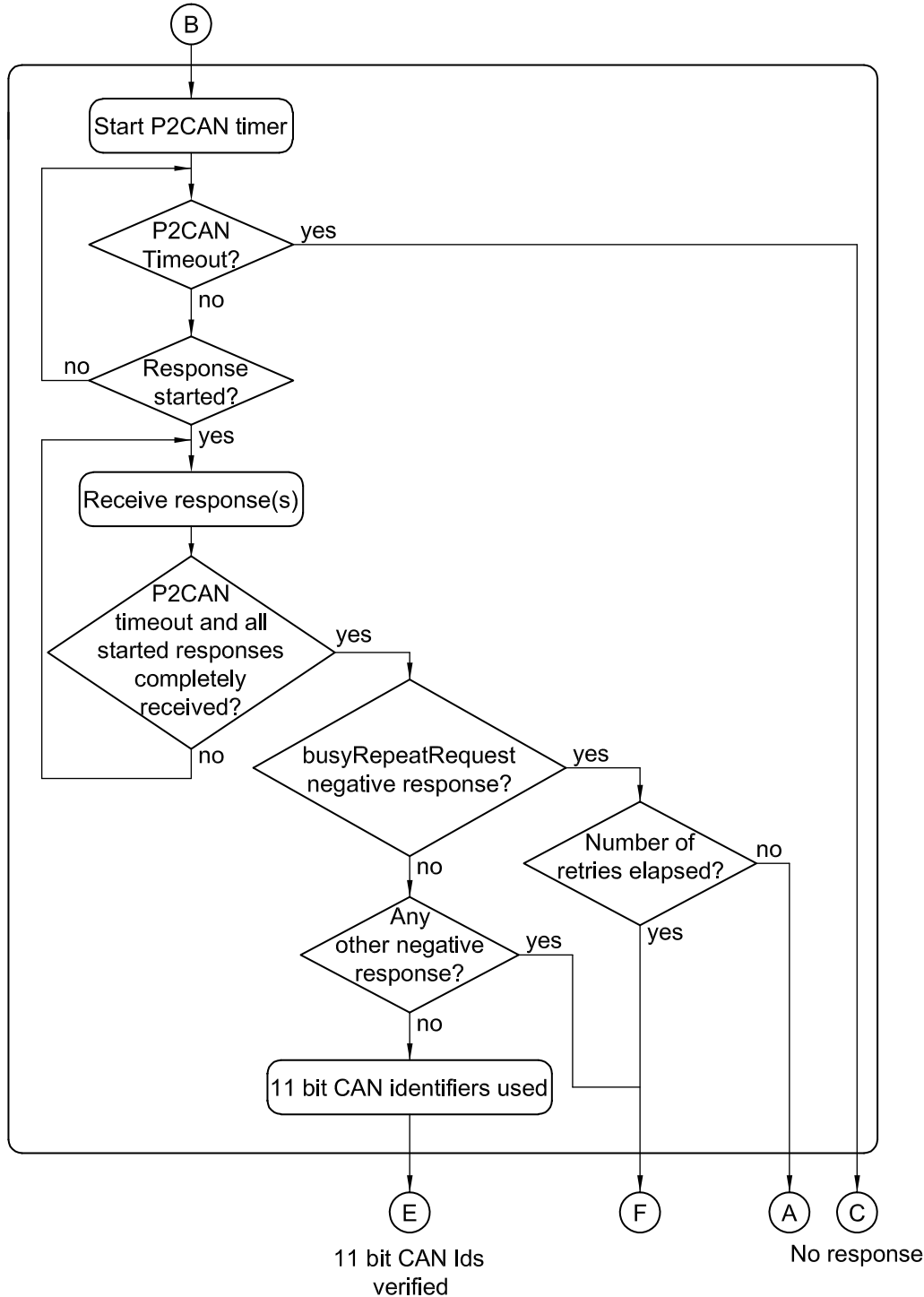

Figure 3 — Initialization sequence — 11 bit CAN identifier response handling

- c) The start of a response message can either be the reception of a FirstFrame or SingleFrame which uses one of the specified legislated-OBD 11 bit physical response CAN identifiers (see 6.3.2.2).

- d) If at least one response message is started, the external test equipment shall continue to receive this previously started response message (only applies to multiple-frame response messages) and shall accept further response messages within $P2_{CAN}$ which use one of the specified legislated-OBD 11 bit physical response CAN identifiers.
- e) When all started response messages are completely received (positive or negative responses) and the $P2_{CAN}$ application timer is timed out, this means that the external test equipment has verified that the vehicle supports legislated OBD on CAN using 11 bit CAN identifiers (connector E). If all received response messages are positive response messages, then the external test equipment knows the supported PIDs and the communication parameters of the legislated-OBD ECUs expected to respond to service 01 hex data parameter requests. Where one or more of the received response messages are negative response messages with response code 21 hex (busyRepeatRequest), the external test equipment shall start the initialization sequence (Connector A) again after a minimum delay of 200 ms. If the negative response(s) appear(s) on six (6) subsequent sequences, the external test equipment will assume that the vehicle is not compliant with ISO 15765-4 (connector F). This means that the legislated OBD-related ECU(s) shall provide a positive response within a maximum of five retries.

4.3 29 bit CAN identifier verification procedure

4.3.1 Request message transmit procedure

The purpose of the 29 bit CAN identifier verification procedure is to determine whether 29 bit CAN identifiers are being used in legislated-OBD communication.

The 29 bit CAN identifier request message transmit procedure shall be used to transmit the functionally addressed request message of the 29 bit CAN identifier verification procedure. The same requirements as specified in 4.2.1 apply to the external test equipment when transmitting this request message. The procedure shall be performed as follows. See Figure 4.

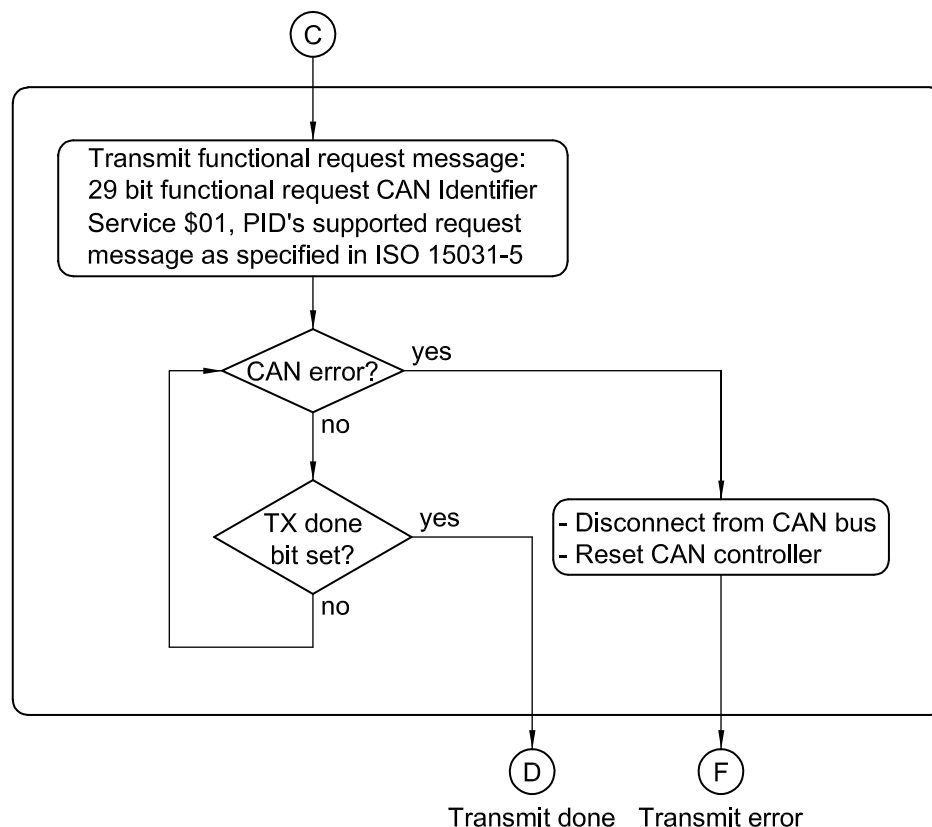

Figure 4 — Initialization sequence — 29 bit CAN identifier request transmission

- a) If the external test equipment reaches this point in the initialization sequence, this means that the CAN baudrate is already configured based on the previously performed 11 bit CAN identifier verification procedure. The external test equipment shall transmit a functionally addressed service 01 hex request message (read-supported PIDs — see ISO 15031-5) using the legislated-OBD 29 bit functional request CAN identifier according to 6.3.2.3. There is no need to set up the CAN Interface.
- b) The external test equipment shall check for any CAN error. If the request message is transmitted onto the CAN bus, it shall indicate a successful transmission (connector D). If a CAN error occurred, the external test equipment shall disconnect its CAN Interface from the CAN bus — with a disconnected CAN interface, the external test equipment shall not be able to transmit dominant bits on the CAN bus — and shall indicate a transmit error (connector F).

4.3.2 Response handling procedure

The 29 bit CAN identifier response handling procedure shall be used to receive 29 bit CAN identifier response messages and indicates that no response message has been received. It shall be performed immediately after the 29 bit CAN identifier request message transmit procedure (4.3.1), as follows. See Figure 5.

- a) If the transmission of the request message was successful (connector D) then the external test equipment shall start the $P2_{CAN}$ (see ISO 15031-5) application timer.
- b) If the external test equipment determines a $P2_{CAN}$ timeout, this means that no response message has been started and the external test equipment has verified that 29 bit CAN identifiers are *not* used for legislated-OBD communication (connector F).
- c) The start of a response message can either be the reception of a FirstFrame or SingleFrame which uses one of the specified legislated-OBD 29 bit physical response CAN identifiers (see 6.3.2.3).
- d) If at least one response message is started, the external test equipment shall continue to receive this previously started response message (only applies to multiple-frame response messages) and shall accept within $P2_{CAN}$ further response messages which use one of the specified legislated-OBD 29 bit physical response CAN identifiers.
- e) When all started response messages are completely received (positive or negative responses) and the $P2_{CAN}$ application timer is timed out, this means that the external test equipment has verified that the vehicle supports legislated OBD on CAN using 29 bit CAN identifiers (connector E). If all received response messages are positive response messages, the external test equipment knows the supported PIDs and the communication parameters of the legislated-OBD ECUs expected to respond to service 01 hex data parameter requests. Where one or more of the received response messages are negative response messages with response code 2 hex (busyRepeatRequest), the external test equipment shall start the initialization sequence (connector C) again after a minimum delay of 200 ms. If the negative response(s) appear(s) on six (6) subsequent sequences, the external test equipment will assume that the vehicle is not compliant with ISO 15765-4 (connector F). This means that the legislated OBD-related ECU(s) shall provide a positive response within a maximum of five (5) retries.

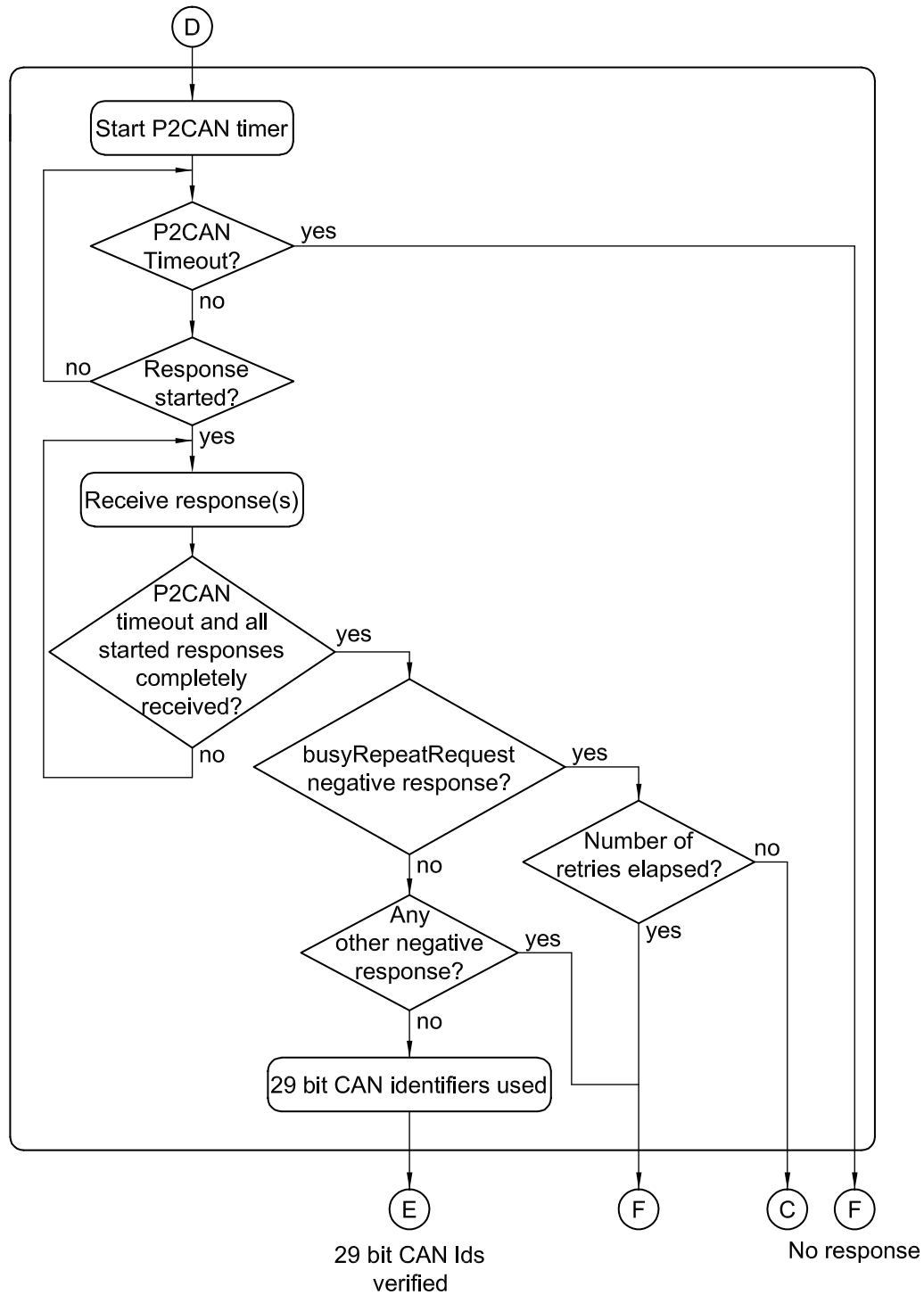

Figure 5 — Initialization sequence — 29 bit CAN identifier response handling

5 Session layer

All legislated OBD shall take place during the default diagnostic session.

There shall always be exactly one diagnostic session active in a legislated OBD-related ECU. A legislated-OBD-related ECU shall always start the default diagnostic session when powered up. If no other diagnostic session is started, then the default diagnostic session shall be running as long as the legislated-OBD-related ECU is powered.

A legislated-OBD-related ECU shall be capable of providing all diagnostic functionality defined for legislated OBD in the default diagnostic session and under normal operating conditions.

There is no need for any diagnostic service to be sent to the legislated-OBD-related ECU to keep the default diagnostic session active.

6 Network layer

6.1 General

The network layer of the external test equipment and the legislated-OBD-compliant vehicle ECU(s) — from the external test equipment point of view — shall be in accordance with ISO 15765-2 and the restrictions/additions given in 6.2 to 6.4.

6.2 Addressing formats

For legislated-OBD communication, only the normal addressing format — in the case of 11 bit CAN identifiers — and only the normal fixed addressing format — in the case of 29 bit CAN identifiers — as they are defined in ISO 15765-2, shall be used.

6.3 Data link layer interface

6.3.1 CAN identifier requirements

6.3.1.1 External test equipment

The external test equipment shall support 11 bit and 29 bit CAN identifiers for legislated-OBD communication, for which it shall only accept CAN identifiers which fit into the defined legislated-OBD CAN identifier ranges for 11 bit or 29 bit CAN identifiers (see 6.3.2).

For legislated-OBD communication following the initialization sequence, the external test equipment shall only use 11 bit or 29 bit CAN identifiers.

6.3.1.2 Legislated-OBD ECU

A legislated-OBD-compliant vehicle shall use a single CAN identifier size: either 11 bit or 29 bit. From the external test equipment point of view, each legislated-OBD ECU in a given legislated OBD-compliant vehicle shall

- support either 11 bit or 29 bit CAN identifiers for legislated-OBD request and response messages,
- support one pair of physical request and response CAN identifiers in accordance with 6.3.2,
- accept the functional request CAN identifier of the supported CAN identifier set (11 bit or 29 bit — see 6.3.2) for functionally addressed legislated-OBD request messages, and
- accept the physical request CAN identifier associated with the physical response CAN identifier for physically addressed FlowControl frames sent by the external test equipment (see 6.3.2).

6.3.2 Mapping of diagnostic addresses

6.3.2.1 Legislated-OBD CAN identifiers

The following subclauses specify the 11 bit and 29 bit CAN identifiers to be used for legislated-OBD diagnostics. Both sets of CAN identifiers represent the mapping of diagnostic addresses into CAN identifiers as follows. Table 2 defines the diagnostic addresses versus type of CAN identifier, whether physical or functional. For 11 bit CAN identifiers, the mapping of the target address (TA) and source address (SA) into a CAN identifier is implied. Table 3 specifies the 11 bit CAN identifiers to be used for legislated-OBD diagnostics. See Figure 6.

Table 2 — Definition of diagnostic addresses versus type of CAN identifier

CAN identifier	Target Address (TA)	Source Address (SA)	TA type (TAtype)	Message type (Mtype)
Functional request	Legislated OBD system = 33 hex	External test equipment = F1 hex	functional	diagnostics
Physical response	External test equipment = F1 hex	Legislated-OBD ECU = xx hex	physical	diagnostics
Physical request	Legislated OBD ECU = xx hex	External test equipment = F1 hex	physical	diagnostics
xx hex ECU physical diagnostic address				
NOTE For detailed descriptions of parameters TA, SA, TAtype and Mtype, see ISO 15765-2.				

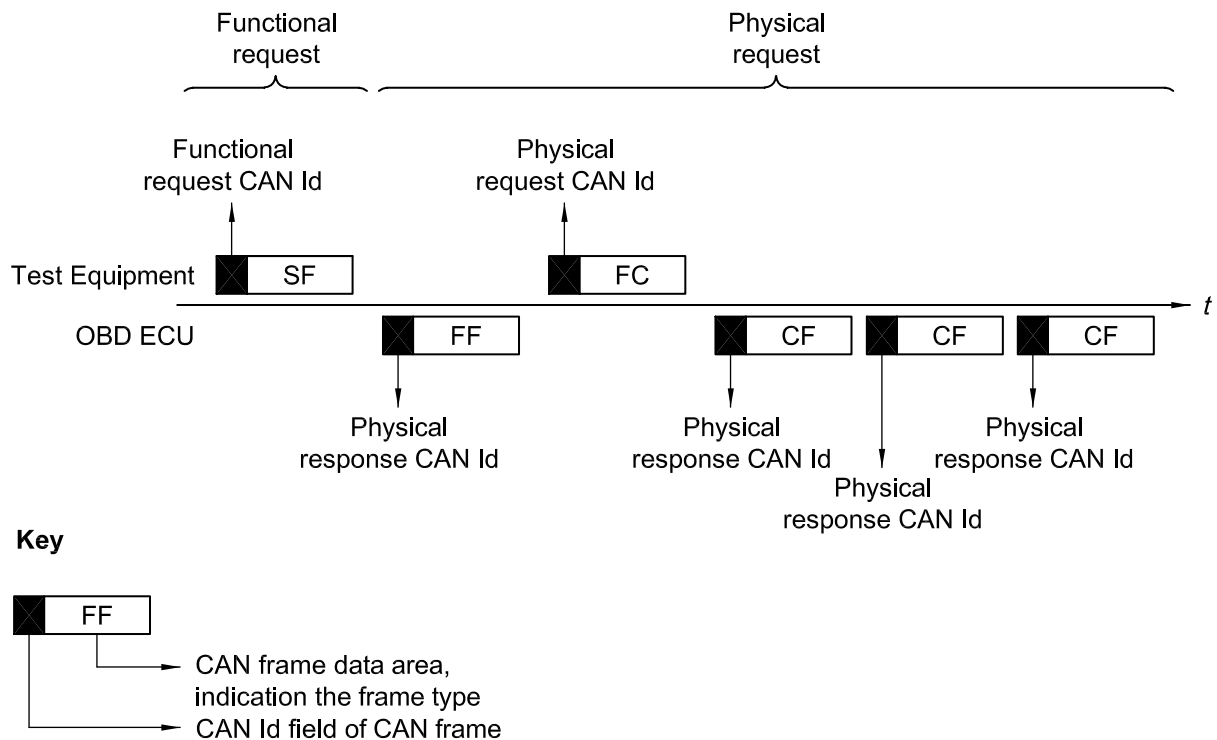

Figure 6 — CAN identifier usage

For legislated OBD:

- the functional request CAN identifier shall be used for functionally addressed request messages sent by the external test equipment, this particular CAN identifier representing the TA 33 hex (legislated-OBD functional system) and SA F1 hex (external test equipment);
- the physical response CAN Id shall be used for physically addressed response messages sent by the legislated-OBD ECU(s), this particular CAN identifier representing TA F1 hex (external test equipment) and the physical diagnostic address (SA) of the ECU(s).
- the physical request CAN Id shall only be used for physically addressed FlowControl frames sent by the external test equipment, this particular CAN identifier representing the physical diagnostic address (TA) of the ECU and SA F1 hex (external test equipment).

The server identifier (physical diagnostic address) of a legislated-OBD ECU shall be unique to a given legislated-OBD-compliant vehicle.

The CAN identifiers specified for legislated OBD may also be used for enhanced diagnostics if this usage does not interfere with legislated OBD.

6.3.2.2 11 bit CAN identifiers

Table 3 specifies the 11 bit CAN identifiers for legislated OBD, based on the defined mapping of the diagnostic addresses.

Table 3 — 11 bit legislated-OBD CAN identifiers

CAN identifier (hex)	Description
7DF	CAN identifier for functionally addressed request messages sent by external test equipment
7E0	Physical request CAN identifier from external test equipment to ECU #1
7E8	Physical response CAN identifier from ECU #1 to external test equipment
7E1	Physical request CAN identifier from external test equipment to ECU #2
7E9	Physical response CAN identifier from ECU #2 to external test equipment
7E2	Physical request CAN identifier from external test equipment to ECU #3
7EA	Physical response CAN identifier from ECU #3 to external test equipment
7E3	Physical request CAN identifier from external test equipment to ECU #4
7EB	Physical response CAN identifier ECU #4 to the external test equipment
7E4	Physical request CAN identifier from external test equipment to ECU #5
7EC	Physical response CAN identifier from ECU #5 to external test equipment
7E5	Physical request CAN identifier from external test equipment to ECU #6
7ED	Physical response CAN identifier from ECU #6 to external test equipment
7E6	Physical request CAN identifier from external test equipment to ECU #7
7EE	Physical response CAN identifier from ECU #7 to external test equipment
7E7	Physical request CAN identifier from external test equipment to ECU #8
7EF	Physical response CAN identifier from ECU #8 to external test equipment

While not required for current implementations, it is strongly recommended (and may be required by applicable legislation) that for future implementations the following 11-bit CAN identifier assignments be used:

- 7E0/7E8 for ECM (engine control module);
- 7E1/7E9 for TCM (transmission control module).

6.3.2.3 29 bit CAN identifiers

Tables 4 and 5 specify the 29 bit CAN identifiers for legislated OBD, based on the defined mapping of the diagnostic addresses. The 29 bit CAN identifiers shall comply with the normal fixed addressing format according to ISO 15765-2, summarized in Table 4.

Table 4 — Summary of 29 bit CAN identifier format — Normal fixed addressing

CAN Id bit position	28	24	23	16	15	8	7	0
Functional CAN Id	18 hex		DB hex		TA			SA
Physical CAN Id	18 hex		DA hex		TA			SA

NOTE The CAN identifier values given in this table use the default value for the priority information in accordance with ISO 15765-2.

Table 5 — 29 bit legislated-OBd CAN identifiers

CAN identifier (hex)	Description
18 DB 33 F1	CAN identifier for functionally address request messages sent by external test equipment.
18 DA xx F1	Physical request CAN identifier from external test equipment to ECU #xx
18 DA F1 xx	Physical response CAN identifier from ECU #xx to external test equipment

The maximum number of legislated-OBd ECUs in a legislated-OBd-compliant vehicle shall not exceed eight (8). The physical ECU diagnostic address of an ECU ('xx' hex) embedded in the physical CAN identifiers shall be unique for a legislated-OBd ECU in a given vehicle.

While not required for current implementations, it is strongly recommended (and may be required by applicable legislation) that for future implementations the physical ECU addresses according to the assignments found in SAE 32178/1.

6.4 Network layer parameters

6.4.1 Network layer timing parameter values

Table 6 specifies the network layer timing parameters to be used by the external test equipment and the legislated-OBd-compliant vehicle — from the external test equipment point of view — for legislated-OBd communication.

The listed performance requirement values are the binding communication requirements for the external test equipment and the legislated-OBd ECU(s) considered as being legislated-OBd-compliant. The timeout values are defined to be higher than the values for the performance requirements in order to overcome communication conditions where the performance requirement absolutely cannot be met (owing to external conditions such as high bus load).

Table 6 — Network layer timeout and performance requirement values

Parameter	Timeout value	Performance requirement value
N_As/ N_Ar	25 ms	—
N_Bs	75 ms	—
N_Br	—	$(N_{Br} + N_{Ar}) < 25 \text{ ms}$
N-Cs	—	$(N_{Cs} + N_{As}) < 50 \text{ ms}$
N-Cr	150 ms	—
Owing to application layer timing requirements, the following performance requirement for the transmission of a single or first frame of an ECU response message applies: $P2_{CAN, ECU} + N_{As} \leq P2_{CANmax}$		
NOTE 1	For a detailed description of the network layer timing parameter values, see ISO 15765-2.	
NOTE 2	For a detailed description of the application layer timing parameter P2, see ISO 15031-5.	

6.4.2 Definition of external test equipment network layer parameter values

The external test equipment shall use the following network layer parameter values for its FlowControl frames sent in response to the reception of a FirstFrame. See Table 7.

Table 7 — External test equipment network layer parameter values

Parameter	Name	Value	Description
N_WFT _{max}	WaitFrame Transmission	0	No FlowControl wait frames are allowed for legislated OBD. The FlowControl frame sent by the external test equipment following the FirstFrame of an ECU response message shall contain the FlowStatus FS set to 0 (ClearToSend), which forces the ECU to start immediately after the reception of the FlowControl frame with the transmission of the ConsecutiveFrame(s).
BS	BlockSize	0	A single FlowControl frame shall be transmitted by the external test equipment for the duration of a segmented message transfer. This unique FlowControl frame shall follow the FirstFrame of an ECU response message.
ST _{min}	SeparationTime	0	This value allows the ECU to send ConsecutiveFrames, following the FlowControl frame sent by the external test equipment, as fast as possible.

If a reduced implementation of the ISO 15765-2 network layer is done in a legislated-OBD ECU, covering only the above listed FlowControl frame parameter values (BS, ST_{min}), then any FlowControl frame received during legislated-OBD communication and using different FlowControl frame parameter values as defined in this table shall be ignored by the receiving legislated-OBD ECU (treated as an unknown network layer protocol data unit).

6.4.3 Maximum number of legislated-OBD ECUs

The maximum number of legislated-OBD-related ECUs in a vehicle shall not exceed eight (8). The network layer of the external test equipment shall be capable of receiving segmented data from eight (8) legislated-OBD ECUs in parallel.

7 Data link layer

All of ISO 11898-1 is applicable for legislated-OBD purposes, with the following restrictions/additions. The external test equipment CAN controller shall be able to transmit and receive 11 bit and 29 bit CAN identifiers (see 6.3).

The CAN DLC (data length code) contained in every diagnostic CAN frame shall always be set to eight (8). The unused data bytes of a CAN frame are undefined. Any diagnostic CAN frame with a DLC value less than eight (8) shall be ignored by the receiving entity.

8 Physical layer

8.1 General

The physical layer and physical signalling of the external test equipment shall be in accordance with ISO 11898-1 and ISO 11898-2, with the following restrictions and additions.

8.2 External test equipment baudrates

The external test equipment shall support the legislated-OBD baudrates. These can vary because of legislation. Where the applicable legislation does not specify baudrates, use

250 kBit/s

500 kBit/s

8.3 External test equipment CAN bit timing

8.3.1 CAN bit timing parameter values

The specified CAN bit timing parameter values apply to the external test equipment. The legislated-OBD-compliant vehicle may use different CAN bit timing parameter values to achieve its legislated-OBD-compliant baudrate, however, it shall be able to communicate with the defined external test equipment.

The following specifies the required CAN bit timing parameter settings for the external test equipment based on the timing parameter definitions given in ISO 11898-1. All requirements are specified for operation at 250 kBit/s and 500 kBit/s. The bit timing is according to ISO 11898. The CAN controller shall support the protocol specifications CAN 2.0A (standard format) and CAN 2.0B passive (29 bit ID extended format) and shall be in accordance with ISO 11898.

For example, the enhanced protocol for higher clock tolerance shall be supported (e.g. tolerate 2 bit message intermission) and extended frame messages shall not be disturbed unless bit errors are being detected.

The CAN bit timing parameter values used in this part of ISO 15765 are based on equivalent terms in ISO 11898-1:

t_{SYNCSEG}	= Sync_Seg	= $1 * t_{\text{Q}}$
t_{SEG1}	= Prop_Seg + Phase_Seg1	= $t_{\text{BIT}} - t_{\text{SYNCSEG}} - t_{\text{SEG2}}$
t_{SEG2}	= Phase_Seg2	
t_{SJW}	= resynchronization jump width	
t_{BIT}	= t_{B} (nominal bit time)	
t_{Q}	= time quantum	
SP	= nominal sample point position	= $(1 - t_{\text{SEG2}}/t_{\text{BIT}}) * 100 \%$

NOTE Compliance with the nominal bit time tolerance requirement given in this part of ISO is directly dependent on the CAN system clock tolerance of the external test equipment and the programmed nominal bit time value. In a typical CAN controller, the nominal bit time value must be an integer multiple of its system clock periods. When the programmable nominal bit time value is set exactly to the required nominal bit time value, accuracy is only affected by the system clock tolerance. Otherwise, the accuracy is dependent upon both the deviation of the programmed bit time value from the nominal bit time value and the system clock tolerance. The contributions from drift or ageing of the system clock source and from the inability to achieve the desired nominal bit time value are additive; the bit time tolerance specification must be met after consideration of both.

See Figure 7.

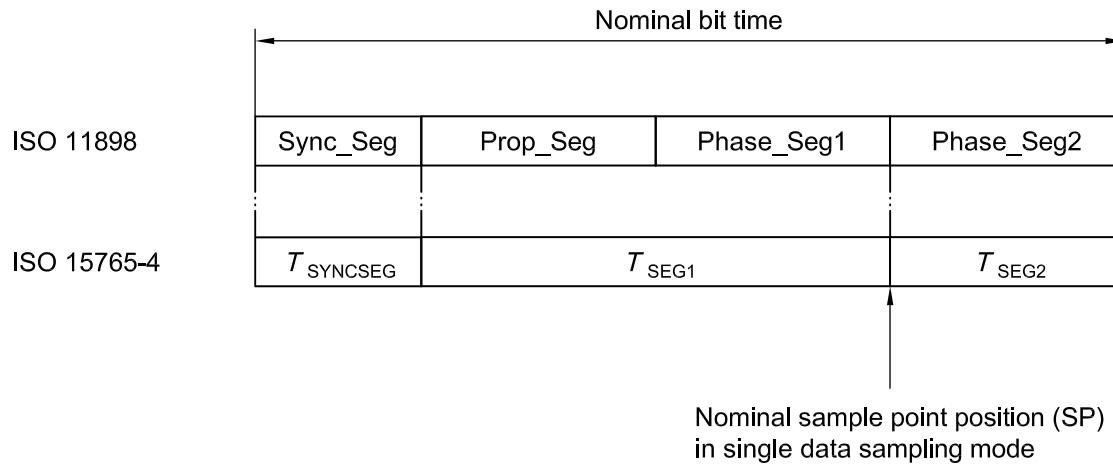

Figure 7 — Partitioning of CAN bit time

8.3.2 Nominal baudrate 250 kBit/s

Table 8 specifies the allowed CAN bit timing parameter values for a baudrate of 250 kBit/s. The external test equipment shall operate in single data sampling mode.

The tolerance of the external test equipment nominal baudrate 250 kBit/s shall be $\pm 0,15 \%$.

Table 8 — 250 kBit/s CAN bit timing parameter values — Single data sampling mode

Parameter	Minimum	Nominal	Maximum
$t_{\text{BIT_RX}}$	3 980 ns	4 000 ns	4 020 ns
$t_{\text{BIT_TX}}$	3 994 ns	4 000 ns	4 006 ns
t_{Q}	—	—	250 ns
Δf	—	—	0,15 %

The min. and max. values of the nominal bit time $t_{\text{BIT_RX}}$ are worst-case values for the reception of bits from the CAN bus based on a nominal baudrate tolerance of $\pm 0,5 \%$. The min. and max. values of the nominal bit time $t_{\text{BIT_TX}}$ are worst-case values for the transmission of bits onto the CAN bus based on the specified external test equipment nominal baudrate tolerance of $\pm 0,15 \%$.

Table 9 presents the only allowed CAN bit timing parameter values for the external test equipment based on standard time quanta (t_{Q}) and the timing parameters listed in 8.3.1.

Table 9 — 250 kBit/s CAN bit timing parameter values for standard time quanta

t_{Q}	t_{SJW}	t_{SEG1}	t_{SEG2}	Nominal sample point position %
ns				
200	600	3 000	800	80
250	750	3 000	750	81,25

The nominal sample point position is specified relative to one (1) bit time.

8.3.3 Nominal baudrate 500 kBit/s

Table 10 specifies the allowed CAN bit timing parameter values for a baudrate of 500 kBit/s. The external test equipment shall operate in single data-sampling mode.

The tolerance of the external test equipment nominal baudrate 500 kBit/s shall be $\pm 0,15\%$

Table 10 — 500 kBit/s CAN bit timing parameter values — Single data sampling mode

Parameter	Minimum	Nominal	Maximum
$t_{\text{BIT_RX}}$	1 990 ns	2 000 ns	2 010 ns
$t_{\text{BIT_TX}}$	1 997 ns	2 000 ns	2 003 ns
t_{Q}	—	—	125 ns
Δf	—	—	0,15 %

The min. and max. values of the nominal bit time $t_{\text{BIT_RX}}$ are worst-case values for the reception of bits from the CAN bus based on a nominal baudrate tolerance of $\pm 0,5\%$.

The min. and max. values of the nominal bit time $t_{\text{BIT_TX}}$ are worst-case values for the transmission of bits onto the CAN bus based on the specified external test equipment nominal baudrate tolerance of $\pm 0,15\%$.

Table 11 presents contains the only allowed CAN bit timing parameter values for the external test equipment based on standard time quanta (t_{Q}) and the timing parameters listed in 8.3.1.

Table 11 — 500 kBit/s CAN bit timing parameter values for standard time quanta

t_{Q}	t_{SJW}	t_{SEG1}	t_{SEG2}	Nominal sample point position %
ns				
100	300	1 500	400	80
125	375	1 500	375	81,25

The nominal sample point position is specified relative to one (1) bit time.

8.4 External test equipment

8.4.1 General

The following specifies the electrical parameters to be fulfilled by the external test equipment. The requirements are separated into those for the external test equipment CAN interface and those for the external-test-equipment cable. See Figure 8.

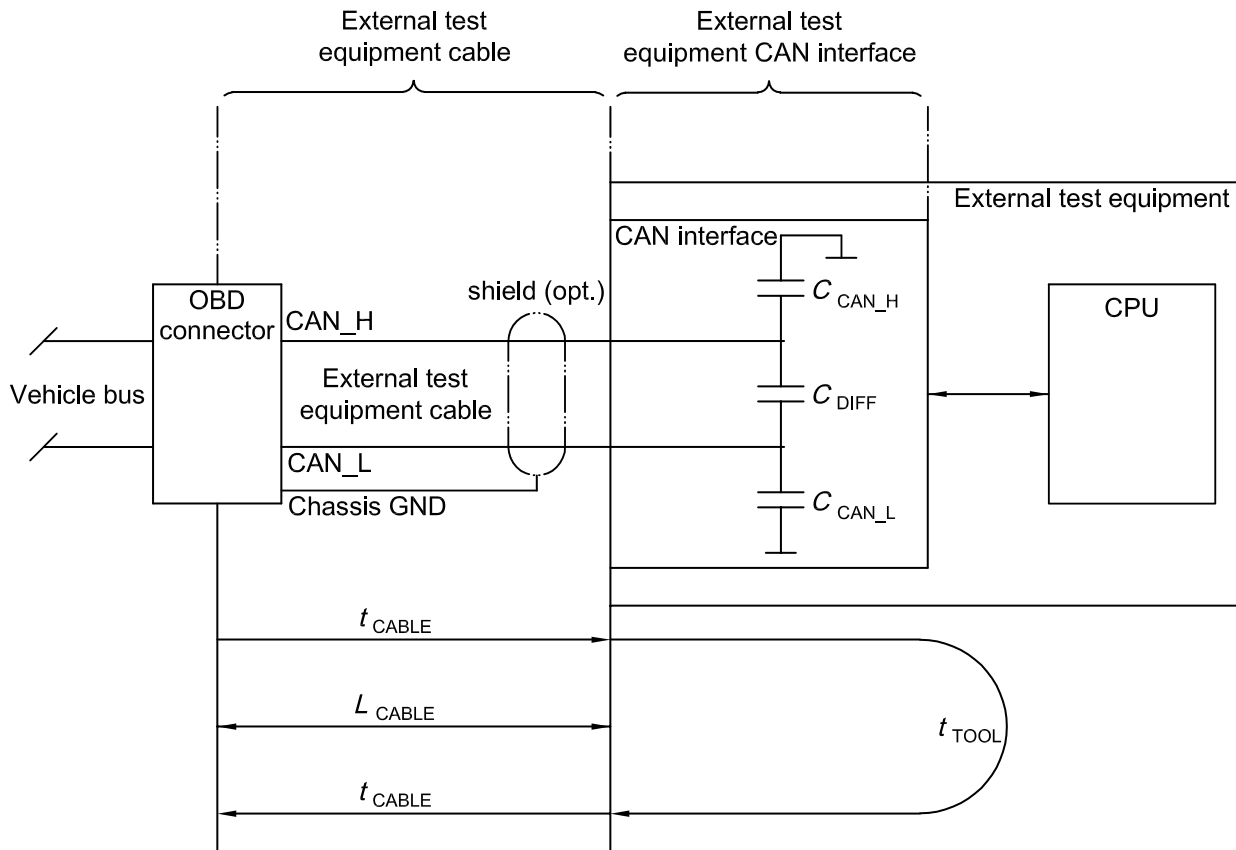

Figure 8 — External test equipment electrical parameters

8.4.2 CAN interface

8.4.2.1 Capacitive load

These subclauses specify the required electrical parameters for the external-test-equipment CAN interface, excluding the cable (see 8.4.3) and the OBD connector.

The external test equipment capacitive load does not include the capacitive load of the external-test-equipment cable. These values only apply to the CAN interface of the external test equipment hardware, with the exception of the a.c. termination (see 8.4.2.3.3), and are seen during the recessive state when the external test equipment is disconnected from the cable and the a.c. termination has not yet been inserted. See Table 12.

Table 12 — External test equipment capacitive load — Without cable capacitive load

Parameter	Minimum	Nominal	Maximum pF	Description
C_{DIFF}	—	—	50	CAN_H to CAN_L
C_{CAN_H} , C_{CAN_L}	—	—	100	CAN_H/CAN_L to ground potential

8.4.2.2 Propagation delay

The external test equipment propagation delay does not include the cable propagation delay. This value only applies to the CAN interface of the external-test-equipment hardware. This requirement is based on the most critical timing when operating at the legislated-OBD compliant baud rate of 500 kbit/s. The external-test-equipment propagation delay (loop delay) includes all delays that can be caused by the CAN interface of the external test equipment (e.g. CAN transceiver propagation delays, CAN controller propagation delays). See Table 13.

Table 13 — External test equipment propagation delay — Loop delay without cable delay

Parameter	Minimum	Nominal	Maximum ns	Description
t_{TOOL}	—	—	390	Loop delay of external test equipment

8.4.2.3 CAN bus termination

8.4.2.3.1 General

These subclauses specify the termination requirements to be fulfilled by the external test equipment. See Figure 9.

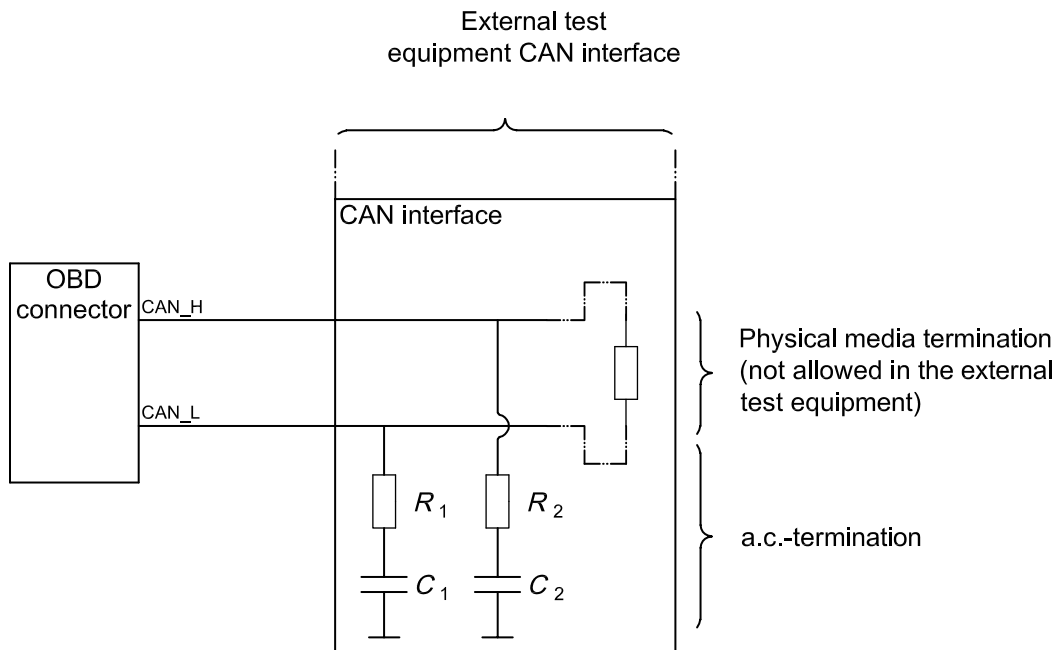

Figure 9 — External test equipment CAN bus termination

8.4.2.3.2 Physical media termination

There shall be no termination resistor between the CAN conductors CAN_H and CAN_L in the external test equipment for the adaptation to the physical media impedance. The external test equipment shall be an unterminated node on the CAN bus to which it is connected.

8.4.2.3.3 a.c. termination

The external test equipment shall have an a.c. termination for the purpose of minimizing reflections on the CAN bus. See Table 14.

NOTE Reflections on the CAN bus occur in the external test equipment CAN interface because it is not permitted that the external test equipment use a physical media termination resistor to adapt to the physical media impedance (8.4.2.3.2).

Table 14 — External-test-equipment a.c. termination parameters

Parameter	Minimum	Nominal	Maximum	Description
R_1, R_2	90 Ω	100 Ω	110 Ω	Resistor of the a.c. termination
C_1, C_2	470 pF	560 pF	640 pF	Capacitor of the a.c. termination
$R_1 = R_2$ $C_1 = C_2$				

8.4.3 External-test-equipment cable

8.4.3.1 Cable length

The external-test-equipment cable shall provide interconnection between the vehicle OBD connector and the CAN interface of the external test equipment (see 8.4.2).

The external-test-equipment cable length is defined to be the length of the cable between the OBD connector and the external test equipment CAN interface. See Table 15.

Table 15 — External-test-equipment cable length

Parameter	Minimum	Nominal	Maximum m	Description
L_{CABLE}	—	—	5	External-test-equipment cable length

8.4.3.2 Propagation delay

The cable propagation delay shall not include the external test equipment propagation delay. This value only applies to the cable. This requirement is based on the most critical timing when operating at the legislated-OBD compliant baudrate of 500 kbit/s. The cable propagation delay is defined as a one-way delay, from the OBD connector to the external test equipment CAN interface. See Table 16.

Table 16 — External-test-equipment cable propagation delay

Parameter	Minimum	Nominal	Maximum ns	Description
t_{CABLE}	—	—	27,5	External-test-equipment cable delay

8.4.3.3 Cable configuration requirements

The following configuration requirements apply to the external-test-equipment cable.

- No other wires shall be twisted with CAN conductor(s) CAN_H or CAN_L. However, twisting of the CAN conductors with Signal Ground is allowed.

NOTE There are no further requirements for twisting.

- The CAN_H and CAN_L conductors shall have the same length and traverse the same path for the entire distance.
- CAN_H and CAN_L conductors shall not be included in a bundle containing radiating wires which induce more than 0,5 V noise modulation on either CAN conductor relative to Signal Ground.
- The cable shall be shielded where the external-test-equipment cable length exceeds 1 m. The shield shall be connected to the chassis ground pin of the cable side of the OBD connector.

Bibliography

- [1] ISO/IEC 7498 (all parts), *Information technology — Open Systems Interconnection — Basic Reference Model*
- [2] ISO/IEC 10731, *Information technology — Open Systems Interconnection — Basic Reference Model — Conventions for the definition of OSI services*
- [3] ISO 15031-3, *Road vehicles — Communication between vehicle and external equipment for emissions-related diagnostics — Part 3: Diagnostic connector and related electrical circuits, specification and use*
- [4] SAE J2178/1, *Class B data communication network messages — Detailed header formats and physical address assignments*

Vertical line of text, possibly a page number or identifier, oriented vertically.

ICS 43.040.15

Price based on 21 pages